



INTERNATIONAL JOURNAL OF ENGINEERING SCIENCES & RESEARCH TECHNOLOGY

Patch Antenna using Metamaterial Structure for Performance Specification

Rahul Rajoria

Department of Electronics, MPCT, Gwalior, India

r_rajoria@yahoo.co.in

Abstract

In this work, The drawback of Patch Antenna was impedance bandwidth. For this purpose, Rectangular microstrip patch antenna loaded with metamaterial structure has been proposed for improving the bandwidth by using CST MICROWAVE STUDIO in this paper. The proposed antenna is designed at a height 3.2 from the ground plane by using CST MICROWAVE STUDIO. The bandwidth of Microstrip patch antenna is 12 .1MHz and return loss is -10.36 dB at a band.The bandwidth of desired antenna is increased up 63.7 MHz at 2.865 GHz. The return loss of proposed antenna is reduced up to - 27.48 dB at 2.865 GHz. This proposed design has small size, easy to fabricate and better directivity.

Keywords: Recangular microstrip patch antenna(RMPA), Impedance Bandwidth , Metematerials.

Introduction

Antenna have been around for a long time, millions of years, as the organ of touch or feeling of animal, birds and insects. But in the last 100 years they have acquired a new significance as the connection link between a radio system and the outside World. The first radio Antenna were built by Heinrich Hertz, a professor at the Technical Institute in Karlsruhe, Germany.

The IEEE standard defines an antenna as a part of a transmitting or receiving system that is designed to radiate or to receive electromagnetic waves [1].

Microstrip antennas have unique features and attractive properties such as low profile, light weight, compactness and Conformability in structure. With those advantages, the antennas can be easily fabricated and integrated in solid-state devices. Microstrip antennas are widely applied in radio frequency devices with singleended signal operation. This has recently been used in microwave design with a combination of metamaterials, either as a cover or a substrate [2]. In modern wireless communication systems, the microstrip patch antennas are commonly used in the wireless devices. Therefore, the miniaturization of the antenna has become an important issue in reducing the volume of entire communication system[3]. V.G. Veselago in 1968 provided a theoretical report on the concept of metamaterial (MTM) [4].

The currently popular antenna designs suitable for the applications of wireless local area

network (WLAN) and world-wide interoperability for microwave access Wi-MAX) have been reported [5]. Several techniques and approaches have been introduced to reduce antenna dimensionsb and maintain good radiation properties [6] – [7].

The “patch” is a low-profile, low –gain, narrow – bandwidth antenna. Aerodynamic considerations require low-profile antenna on aircraft and many kinds of vehicles. Typically a patch consists of thin conducting sheet about 1 by $1/2\lambda_0$ mounted on Substrate. Radiation from the patch is like radiation from two slots, at the left and right edges of the patch. The “slot” is the narrow gap between the patch and the ground plane. The patch – to-ground-plane spacing is equal to the thickness t of the substrate and is typically about $\lambda_0/100$. Advantage of patch antenna than several antenna is lightweight and inexpensive.

The electric field is zero at the center of patch, maximum at one side, minimum on the opposite side. The important parameters of any type antenna are impedance bandwidth and return loss. The impedance bandwidth depends on parameters related to the patch antenna element itself and feed used. The bandwidth is typically limited to a few percent. This is a disadvantage of basic patch antenna. Metamaterial based rectangular microstrip patch antenna improves the bandwidth and return loss in significant way. CST MICROWAVE STUDIO is a software package for the electromagnetic analysis and design, use to design the metamaterial based

rectangular microstrip patch antenna. The software contains four different simulation techniques like transient solver, frequency domain solver, integral equation solver, Eigen mode solver and most flexible is transient solver.

Design Specifications

The RMPA parameters are calculated from the following formulas. Desired Parametric Analysis [8][9].

Calculation of Width (W):

$$W = \frac{1}{2f_r \sqrt{\mu_0 \epsilon_0} \sqrt{\epsilon_r + 1}} = \frac{C}{2f_r \sqrt{\epsilon_r + 1}} \tag{1}$$

Where

C = free space velocity of light,
Er = Dielectric constant of substrate

The effective dielectric constant of the rectangular microstrip patch antenna:

$$\epsilon_{eff} = \frac{\epsilon_r + 1}{2} + \frac{\epsilon_r - 1}{2} \left(\frac{1}{\sqrt{1 + \frac{12h}{w}}} \right) \tag{2}$$

Actual length of the patch (L):

$$L = L_{eff} - 2\Delta L \tag{3}$$

Calculation of length extension:

$$\frac{\Delta L}{h} = 0.412 \frac{(\epsilon_{eff} + 0.3) \left(\frac{w}{h} + 0.264 \right)}{(\epsilon_{eff} - 0.258) \left(\frac{w}{h} + 0.8 \right)} \tag{4}$$

Analysis Of Rectangular Microstrip Patch Antenna And Metamaterial Structure With Simulated Results

I. The parameters of RMPA alone are mention in the Table1.

II.

Parameters	Dimensions	Unit
Dielectric Constant (er)	4.3	-
Loss Tangent (tan δ)	0.02	-
Thickness (h)	1.6	Mm
Operating Frequency	2.865	GHz

Length (L)	35	Mm
Width (W)	46	Mm
Cut Width	6	Mm
Cut Depth	10	Mm
Path Length	33	Mm
Width Of Feed	6	Mm

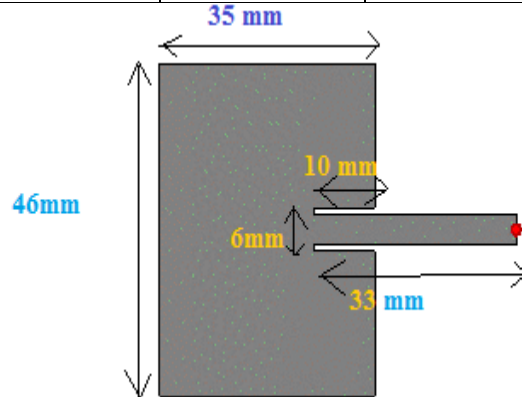

Fig 1: Rectangular microstrip patch antenna(RMPA) designed at 1.764GHz & 2.472 GHz.

The Rectangular microstrip patch antenna is designed by using CST-MWS (computer simulation Technology) software with 1.6 mm height from the ground plane.

The Simulated Results of RMPA alone is bandwidth and return loss shown in figure 2.

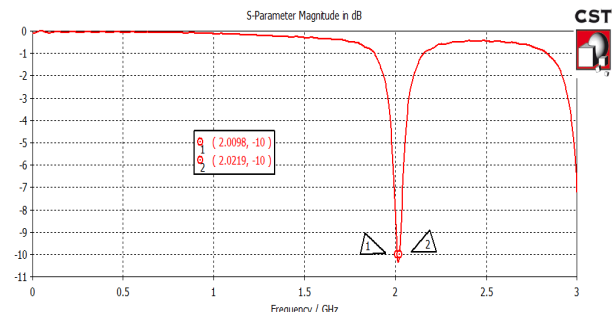

Fig 2. Simulation of return loss and bandwidth of RMPA alone.

The above figure shows that Bandwidth and Return loss of Rectangular microstrip patch antenna (RMPA) are 12.1 MHz and -10.36dB respectively.

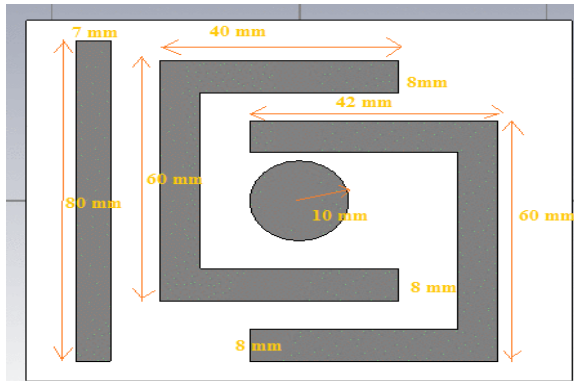

Fig 3. Design of desired metamaterial structure at the height of 3.2 mm from ground plane.

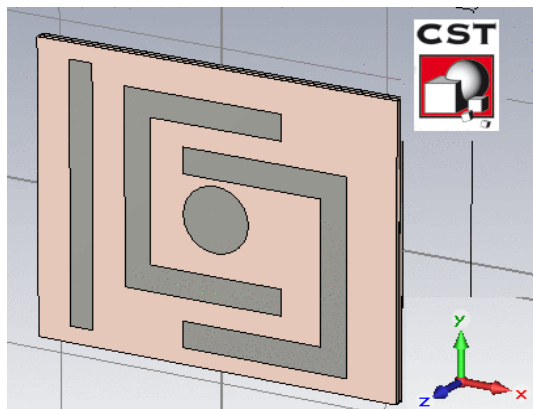

Fig 4. Rectangular microstrip patch antenna with desired metamaterial structure.

In the above figure 3 and figure 4 desired Rectangular microstrip patch antenna design provide the better response in parameters like Impedance Bandwidth, Return loss and Directivity at operating frequency 2.865 GHz in comparison to RMPA alone.

The Metamaterial design is a combination of nine squares shapes on substrate material. Each zero shape is equally distributed with each other from the center. This design is easy to fabricate, cheap, small size and removed the drawback of Rectangular microstrip patch antenna at operating frequency.

The simulated result of desired RMPA alone is shown in below figure 5.

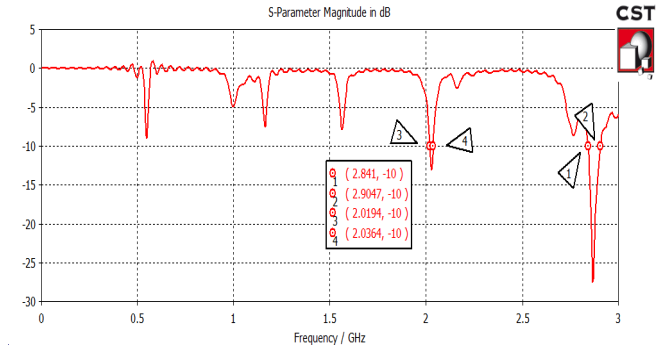

Fig 5. Simulation results of Return loss and impedance bandwidth of RMPA with desired metamaterial structure at 2.865 GHz.

As compared to RMPA alone, the bandwidth of desired antenna is increased up to 63.7 MHz at 2.865 GHz. The return loss is reduced up to -27.48 dB at 2.865 GHz.

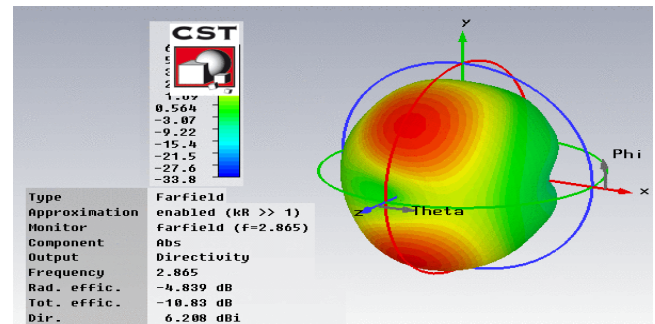

Fig 6. Radiation pattern of RMPA at dual band operation.

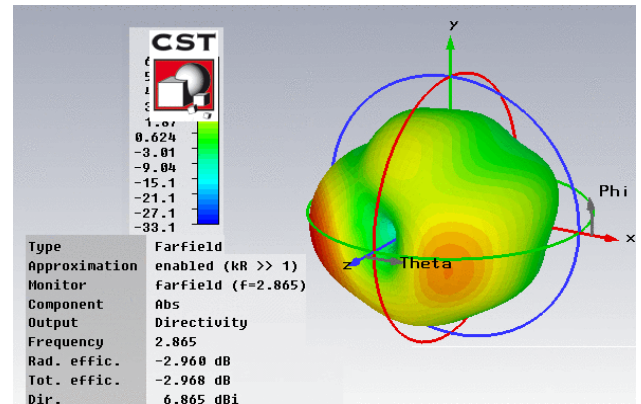

Fig 7. Radiation pattern of desired antenna showing Directivity of 6.865 dBi.

The above figure shows that the directivity of rectangular microstrip patch antenna (RMPA) alone is 6.702 dBi at 2.865 GHz. When compared to RMPA alone, the Directivity of desired antenna is increased from 6.702 dBi to 7.224 dBi at 2.865 GHz.

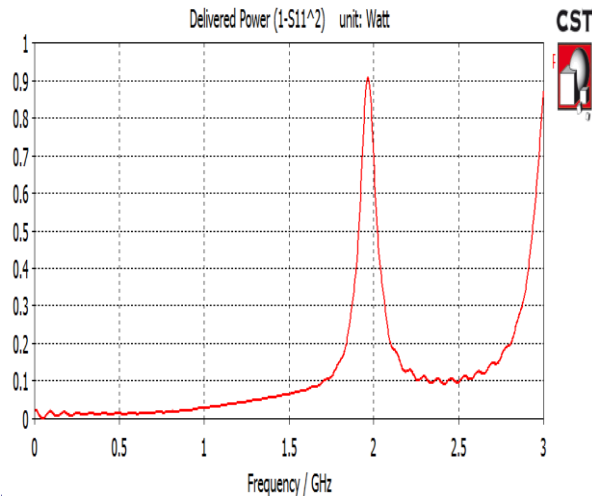

Fig 8. Delivered power to RMPA at operating frequency.

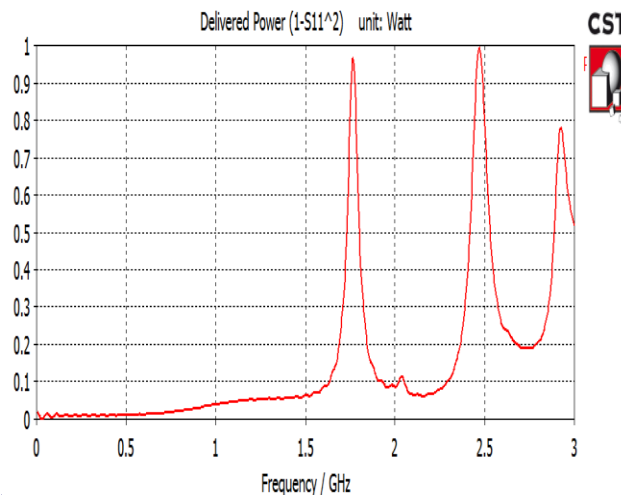

Fig 9. Delivered power to reduced size RMPA loaded with metamaterial structure

The delivered power to RMPA alone is above 0.9 watt. And delivered power to proposed antenna is 1 watt and above 0.95 watt at operating frequency.

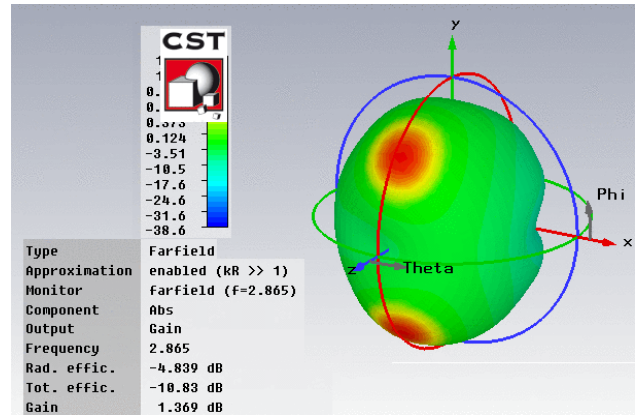

Figure11. gain of the RMPA alone at 2.865 GHz.

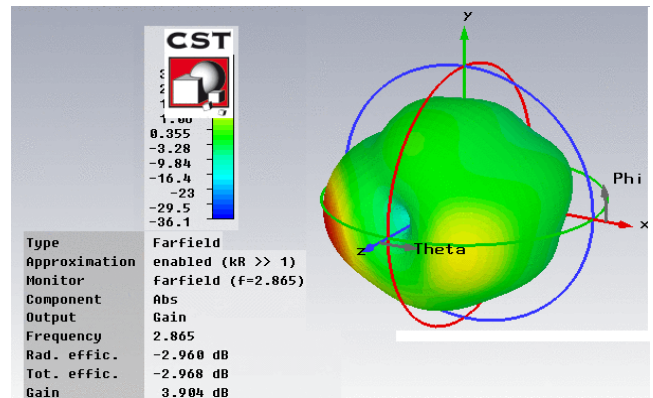

Figure12. gain of the RMPA alone at 2.865 GHz .

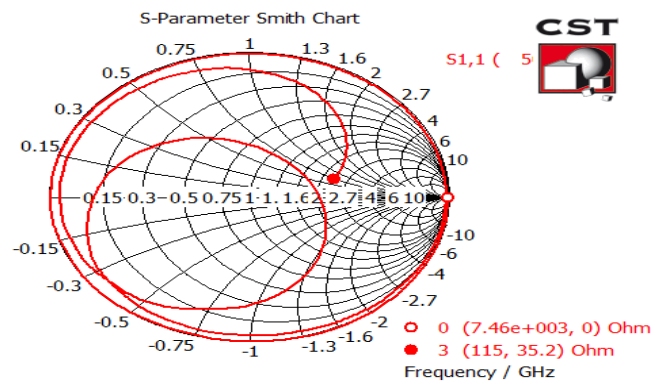

Figure 14. Smith chart of simple Rectangular microstrip patch antenna at operating frequency.

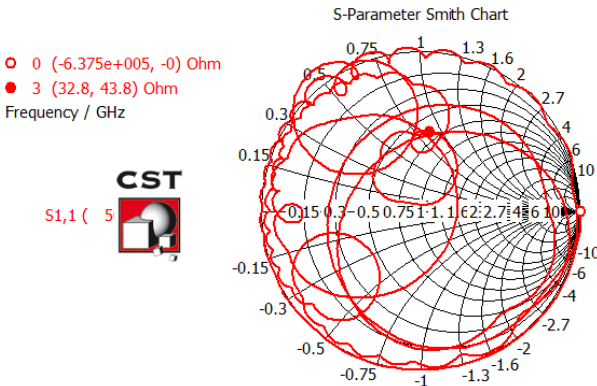

Figure 15. Smith chart of PMPA loaded with metamaterial

The smith chart is very useful when solving transmission problems. The real utility of the Smith chart, it can be used to convert from reflection coefficients to normalized impedances (or admittances), and vice versa. Smith chart of RMPA loaded with metamaterial structure at 2.865 GHz. Above Fig. shows the impedance variation in the simulated frequency range and received impedance matching for proposed antenna at characteristic impedance at dual band.



Fig 16. Microstrip patch antenna on PCB plate.

Simulation Results

In this paper, As compared to RMPA alone, the bandwidth of desired antenna is increased up to 61.7 MHz at 2.925 GHz and 27.4 MHz at 1.965 GHz. The return loss is reduced up to -35.55 dB at 2.925 GHz and -29 dB at 1.965 GHz. The directivity of rectangular microstrip patch antenna (RMPA) alone is 6.702 dBi at 2.925 GHz. When compared to RMPA alone, the Directivity of desired antenna is increased from 6.702 dBi to 7.224 dBi at 2.925 GHz. The delivered power to RMPA alone is above 0.9 watt. And delivered power to proposed antenna is 1 watt and above 0.95 watt at operating frequency. Using

CST-MWS software, the proposed design in comparison to RMPA alone is designed at dual band.

Conclusion

The proposed antenna provide the better improvement in the impedance bandwidth and reduction in the return loss at 2.865 GHz. The drawback of Patch Antenna was impedance bandwidth. For this purpose, Rectangular microstrip patch antenna loaded with metamaterial structure has been proposed for improving the bandwidth by using CST MICROWAVE STUDIO in this paper. By using Metamaterial Structure, the maximum power delivered to desired patch antenna is 1 watt as compared to the RMPA delivered power of 0.9 watt.

Acknowledgment

The authors wish to thank their parents for their constant motivation without which this work would have never been completed. The authors are grateful to the Dr. Ghanshyam Singh, Principal MPCT Gwalior for providing us lab facilities to complete this project work. We also express our gratitude towards Pankaj Shrivastava HOD Dept. of Electronics . MPCT and Gaurav Saxena, Abhishek Lahariya Professor Dept. of Electronics, MPCT for their continued support and guidance.

References

- [1] "IEEE standard definitions of terms for antennas," IEEE Std 145-1983, 1983.
- [2] Y. P. Zhang and J. J. Wang, "Theory and analysis of differentially-driven microstrip antennas," *IEEE Transactions on Antennas and Propagation*, vol. 54, pp. 1092-1099, 2006.
- [3] H.A. Jang, D.O. Kim, and C. Y. Kim " Size Reduction of Patch Antenna Array Using CSRRs Loaded Ground Plane" *Progress In Electromagnetics Research Symposium Proceedings, KL, MALAYSIA, March 27-30, 2012* 1487.
- [4] Veselago, V. G., *The electrodynamics of substances with simultaneously negative values of ϵ and μ* *Soviet Physics Uspekhi*, Vol. 10, No. 4, 509-514, 1968.
- [5] Kuo, Y. L. and K. L. Wong, *Printed double-T monopole antenna for 2.4/5.2 GHz dual-band WLAN operations*, *IEEE Trans. Antennas Propag.*, Vol. 51, No. 9, 2187-2192.
- [6] SKRIVERVIK, A. K., ZÜRCHER, J.-F., STAUB, O., MOSIG, J. R., *PCS antenna design: The challenge of miniaturization. IEEE Antennas and Propagation Magazine*, 2001, vol. 43, no. 4, p. 12-26.

- [7] HIRASAWA, K. *Small antennas for mobile communications. In Proceedings Antenn00, Nordic Antenna Symposium. Lund (Sweden), 2000, p. 11–15.*
- [8] Constantine A. Balanis, *Antenna Theory and Design, John Wiley & Sons, Inc., 1997.*
- [9] W.L. Stutzman, G.A. Thiele, *Antenna Theory and design, John Wiley & Sons, 2nd Ed., New York, 1998.*